

GRAZIE THANK YOU MERCI DANKE GRACIAS GRATIAS TIBI ありがとう 谢谢 TAK
SKAL DU HAVE TAKK SKAL DU HA BEDANKT DIOLCH KIITOS Ви
благодарам Спасибо Дякую გმადლობთ Хвала вам ചെമ്പരല
NGIYBONGA HVALA VAM நன்றி ASANTE HATUR NUHUN MAHADSANID
ĎAKUJEM GO RAIBH MAITH AGAT धन्यवाद TERIMA KASIH DANKIE
ευχαριστώ شكراً لك OBRIGADO 감사합니다 Cãm ơn WEEBALE баярлалаа
köszönöm TACK धन्यवाद Teşekkürler תודה Tapadh leat Aciù aitäh धन्यवाद

EXPLORING THE BORDERS

MUSIC, PURE SOUND, THERAPEUTIC SOUND, ENVIRONMENTAL
SOUND, SOUND ART, SOUND DESIGN, MEDITATIVE SOUND, AMBIENT,
NOISE, LISTENING, PLAYING, PERFORMANCE, RESEARCH,
COMPOSITION, IMPROVISATION, RHYTHM, FREQUENCY, PERCUSSION,
DRONE.....



THANKS VERY MUCH FOR PURCHASING 23 PSYCHOACOUSTIC SYNTH.

THIS INSTRUMENT OFFERS A DEEP USER INTERFACE THAT IS FULLY MODULAR.

FIRST THING TO KNOW IS THAT IN ORDER TO GET ANY SOUND OUT OF THE UNIT, ONE OF THE SOUND PRODUCING SECTIONS MUST BE PATCHED TO ONE OF THE ASSIGNABLE 3.5MM JACKS

-----POWER SUPPLY 12V CENTER POSITIVE -----

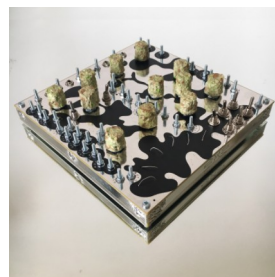

DUE TO THE NATURE OF TWIN T FILTERS COMBINED WITH THE EXPOSED PATCHING INTERFACE, THERE CAN BE GROUND HUM ISSUES

IF YOU USE A 12V USB POWER BOOSTER CABLE WITH A 5V USB WALL CHARGER AND 23.

IF THE UNIT GETS WET, TURN IT OFF IMMEDIATELY AND LET IT DRY OUT BEFORE RESTARTING.

23 ACCEPTS AND OUTPUTS POSITIVE CONTROL VOLTAGE SIGNALS IN THE RANGE OF 0-10V.

USE WITH 0-10V EURORACK OR OTHER SIMILAR SYNTH EQUIPMENT OR STANDARD EFFECTS UNITS, MIXERS, SAMPLERS, AUDIO INTERFACES ETC...

DON'T CONNECT HIGH VOLTAGES LIKE THE OUTPUT OF A POWER AMPLIFIER TO THE UNIT FOR EXAMPLE. IN SUCH SITUATIONS I ASSUME NO RESPONSIBILITY.

FOR ANY SERVICE REQUIREMENTS DON'T HESITATE TO GET IN TOUCH WITH ME INFO@TWINTROPIQUES.COM

UN SALUTO

X

NICOLAS

-----TOUCH SENSORS-----

THE TOUCH SENSORS WORK BECAUSE OUR BODIES ARE ALWAYS CONTACTING WITH GROUND. THE PRECISE ELECTRO MAGNETIC STATE OF OUR BODIES IS DEPENDENT ON OTHER THINGS AS WELL, FOR EXAMPLE HUMIDITY IN THE AIR AND EVEN EMOTIONAL STATE. 23'S FACEPLATE AND BODY ARE GROUNDED. IF YOU EXPERIENCE UNEXPECTED BEHAVIOUR FROM 23 TOUCH SENSORS, COUPLE YOUR BODY TO GROUND BY TOUCHING THE METAL AREAS ON THE FACEPLATE OR THE CASE OF THE SYNTH.

THE TOUCH SENSORS CAN BE LEFT IN A PERMANENT ON STATE BY CONNECTING A PATCH CABLE FROM ANY GIVEN TOUCH SENSOR TO GROUND. IF YOU WANT THE PULSER TO RUN CONTINUOUSLY WITHOUT HAVING TO TOUCH IT FOR EXAMPLE.

-----ASSIGNABLE 3.5MM JACKS-----

THE 5 ASSIGNABLE 3.5MM JACKS ARE MONO, AND PROVIDE THE WAY FOR SOUND AND CONTROL VOLTAGE TO ENTER AND EXIT THE SYNTH. THE PATCH POINTS CORRESPOND TO THE JACK DIRECTLY TO THE RIGHT. THESE PATCH POINTS ARE GROUNDED WHEN NO CABLE IS INSERTED AND CAN BE USED AS EXTRA GROUND CONNECTIONS, FOR KEEPING TOUCH SENSORS IN A PERMANENT ON STATE FOR EXAMPLE.

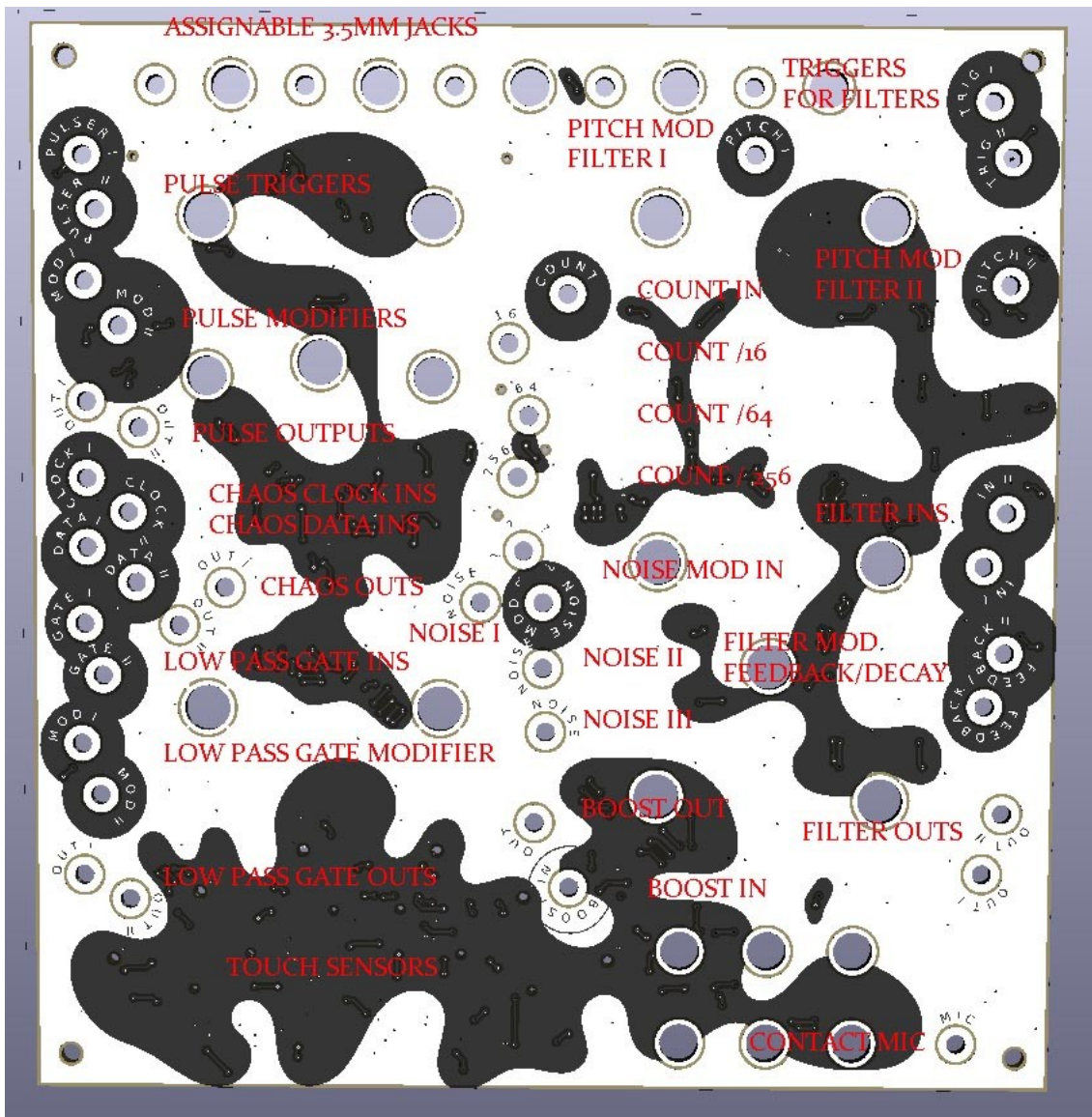

-----PULSERS-----

PULSERS I & II ARE TRIGGERED BY THE TWO OUTERMOST TOUCH SENSORS. THESE TOUCH SENSORS PRODUCE GATES WHICH TRIGGERS THE PULSERS TO SEND OUT PULSES. THESE GATES CAN BE FOUND AT THE PATCH POINTS LABELED PULSER I AND PULSER II RESPECTIVELY. PULSER I AND PULSER II PATCH POINTS CAN ALSO BE USED AS INPUTS TO TRIGGER THE PULSERS EITHER FROM OTHER GEAR OR FROM OTHER TOUCH SENSORS. FOR EXAMPLE YOU WANT TO TRIGGER PULSER I AT THE SAME TIME AS FILTER II, YOU WOULD CONNECT PULSER I AND TRIG II. NOW TOUCHING SENSOR FOR PULSER I AND TRIG II WOULD ACTIVATE BOTH PULSER I AND FILTER II.

PULSE MODIFIERS RECEIVE CONTROL VOLTAGES OR CV TO AFFECT THE PULSER'S FREQUENCY.

THERE ARE TWO SWITCHES THAT CHOOSE BETWEEN LOW, SUB AUDIBLE FREQUENCY, AND FASTER AUDIBLE RANGE FREQUENCY. THE TWO KNOBS ABOVE THE SWITCHES CONTROL RATE OF FREQUENCY FOR THE RESPECTIVE PULSERS.

PULSER OUTPUTS ARE WHERE YOU FIND THE PULSES, THESE PATCH POINTS CAN ALSO BE TOUCH CONNECTED BY SKIN TOUCH TO CERTAIN AREAS OF THE SYNTH, FOR EXAMPLE THE FILTER INPUTS.

** ALL INPUTS ON THE SYNTH HAVE BLACK CIRCLES, THE EXCEPTION BEING TRIG I II PULSER I II AND MOD I II SINCE THESE ARE ASSOCIATED TO THE TOUCH SENSORS AND SO ARE BOTH INPUT AND OUTPUT.

-----CHAOS REGISTERS-----

THE CHAOS REGISTERS USE SOMETHING CALLED A SHIFT REGISTER TO CREATE A SEMI-CONTROLLABLE PSEUDO RANDOM VOLTAGE GENERATOR.

CLOCK INPUT FOR THE 2 CHAOS REGISTERS DETERMINES THE SPEED AT WHICH THE REGISTER CHANGES ITS RANDOMIZED OUTPUT.

THE DATA INPUTS DETERMINE WHAT THE ACTUAL VOLTAGE OUTPUT IS. IF THE CLOCK AND THE DATA INPUTS ARE IN SOME WAY NUMERICALLY RELATED TO ONE ANOTHER, FOR EXAMPLE THE DATA IS A DIVISION OF THE CLOCK FREQUENCY, THEN THE "RANDOMIZED" OUTPUT WILL ACTUALLY BE A REPEATING PATTERN.

***IF THE DATA INPUT IS UNPLUGGED, WHATEVER THE LAST 8 STEPS OF DATA ENTERED WERE, WILL LOOP AT THE SPEED OF THE CLOCK.

****BOTH THE CLOCK AND THE DATA INPUT OF THE REGISTER ACCEPT WHAT ARE CALLED LOGIC OR BINARY SIGNALS- THAT IS SIGNALS THAT ARE EITHER IN AN ON OR OFF STATE. THE PULSERS, NOISE OUTPUT I, THE TOUCH SENSORS, AND THE OUTPUTS OF THE COUNTER PRODUCE SUCH SIGNALS.

THE CHAOS REGISTERS ARE ALSO SENT TO THE CAPACITOR SWITCHING SYSTEM OF THE TWIN T FILTERS. WHEN THE CAPACITOR SELECTOR SWITCHES FOR THE 2 TWIN T FILTERS ARE IN THE FAR LEFT POSITION THE CHAOS REGISTER WILL DETERMINE WHICH OF THE 2 POSSIBLE CAPACITOR VALUES FOR THAT SWITCH IS SELECTED. IF ALL THE SWITCHES ARE IN THE FAR LEFT POSITION THE CHAOS REGISTER WILL CYCLE THROUGH ALL 8 CAPACITOR VALUES FOR THAT FILTER.

CHAOS REGISTER I IS SENT TO CAPACITOR SWITCHES OF FILTER II
CHAOS REGISTER II IS SENT TO CAPACITOR SWITCHES OF FILTER I

OUTS I II ARE WHERE YOU FIND THE GENERATED RANDOM VOLTAGES OF EACH CHAOS REGISTER.

-----LOW PASS GATES-----

LOW PASS GATE INPUTS RECEIVE CV OR AUDIO SIGNALS. AT THE INPUT OF EACH GATE IS AN ATTENUATOR CONTROLLED BY THE 2 KNOBS DIRECTLY ABOVE THE TOUCH SENSORS. THIS IS VERY USEFUL FOR PROCESSING CV TO BE SENT TO THE PITCH INPUTS OF THE FILTERS AND FOR MIXING AUDIO SIGNALS. YOU CAN CONNECT THE TOUCH SENSOR FOR THE RESPECTIVE GATE TO GROUND TO LEAVE THE GATE OPEN AND ONLY USE IT FOR ITS ATTENUATION FUNCTION.

LOW PASS GATE MODIFIERS CAN RECEIVE CV TO OPEN THE GATE OR OUTPUT THE GATE SIGNAL PRODUCED WHEN THE SENSORS FOR THE GATE MODIFIERS ARE TOUCHED.

GATE OUTPUTS ARE THE OUTPUTS FOR THE GATES AND CAN BE CONNECTED DIRECTLY WITH THE FILTER OUTPUTS FOR AUDIO SIGNAL MIXING

-----COUNTER-----

COUNT IN IS THE INPUT FOR THE COUNTER AND ACCEPTS A BINARY SIGNAL SUCH AS TOUCH SENSORS, PULSERS, OR NOISE I. THE CHAOS REGISTER OUTPUTS CAN ALSO BE USED TO DRIVE THE COUNTER EVEN THOUGH THEY ARE NOT BINARY.

OUTPUTS DIVIDE THE INPUT BY 16, 64, AND 256 RESPECTIVELY

-----NOISE-----

NOISE MODIFIER ACCEPTS CV. THE MODIFIER CAN BE OFFSET BY THE NOISE CONTROL KNOB WHICH IS LOCATED BETWEEN THE TWO PULSER RANGE SWITCHES. AT THE EXTREME ENDS OF THE KNOB WILL BE SILENCE. AS YOU APPROACH THE CENTER OF THE KNOB FROM EITHER DIRECTION THE NOISE DENSITY WILL BECOME HIGHER GOING FROM SPORADIC CRACKLING TO FULL ON WHITE NOISE.

NOISE OUTPUT I IS THE STRONGEST OUTPUT AND CAN BE USED TO DRIVE THE COUNTER OR THE CHAOS CLOCK OR DATA. IT IS UNFILTERED AND UNATTENUATED

NOISE OUTPUT II IS HIGH PASS FILTERED AND ATTENUATED

NOISE OUTPUT III IS HIGH PASS FILTERED AND ATTENUATED EVEN MORE

ANY OF THE NOISE OUTPUTS CAN BE MIXED WITH THE FINAL OUTPUT. I THINK ITS A GOOD IDEA TO RUN THEM THROUGH THE GATES TO ATTENUATE THE SIGNAL SO IT DOESN'T OVER POWER THE OTHER SECTIONS. THE NOISE OUTPUTS CAN ALSO BE MIXED INTO THE TOTAL OUTPUT JUST BY TOUCH. TOUCH FOR INSTANCE NOISE OUTPUT I OR II AND AT THE SAME TIME TOUCH FILTER I OR II PITCH OR IN PATCH POINTS AND SEE WHAT HAPPENS.

-----FILTERS-----

TRIG I II ARE THE TRIGGER INPUTS FOR THE 2 FILTERS. TOUCH SENSORS GATES CAN ALSO BE ACCESSED HERE AS WITH ANY OF THE OTHER SECTIONS' TOUCH SENSOR IN/OUT.

PITCH MOD I II RECEIVE CV SIGNAL FOR PITCH. AS WITH ALL OTHER CV INPUTS ON 23, CV IS POSITIVE SO IF THE PITCH KNOB IS ALREADY ALL THE WAY TO THE RIGHT, CV WILL HAVE NO EFFECT. PITCH MOD IS ALSO EXTREMELY NON LINEAR AND FINE TUNED MODULATION REQUIRES USE OF AN ATTENUATOR IN THE LOW PASS GATE SECTION.

FILTER IN I II ARE GENERAL INPUTS TO THE TWIN T NETWORK OF THE CIRCUITS. FOR EXAMPLE, YOU CAN SEND AUDIO IN HERE TO BE FILTERED. OR IF YOU HAVE EXTERNAL GEAR THAT PRODUCES TRIGGERS YOU CAN SEND TRIGGERS INTO AN ATTENUATOR TO GET DIFFERENT IMPACT RESPONSES. TOUCHING THESE PATCHPOINTS WILL ALSO SEND THE FILTERS INTO SELF OSCILLATION.

FEEDBACK I II RECEIVE CV INPUTS FOR FEEDBACK/DECAY TIME. ON MOST CAPACITOR SETTINGS IF FEEDBACK KNOB IS ALL THE WAY LEFT CV EFFECT WILL BE HARDLY AUDIBLE AND IF FAR RIGHT THE FILTER WILL BE IN SELF OSCILLATION AND AGAIN THE EFFECT WILL NOT BE AUDIBLE. ITS USUALLY NECESSARY TO MOVE THE KNOB TOWARD THE 9PM-10 O CLOCK REGION TO GET A NICE CV RESPONSE. THIS IS A VERY USEFUL PATCH POINT CAPABLE OF PRODUCING SOME REALLY NICE SOUNDS.

OUTPUTS I II ARE OF COURSE THE OUTPUTS FOR THE TWIN T FILTERS. THEY CAN BE PASSIVELY MIXED TOGETHER JUST BY CONNECTING OUTPUT I AND OUTPUT II PATCH POINTS AND THIS IS IN FACT MY RECOMMENDATION FOR HOW TO SEND AUDIO OUT OF THE SYNTH. YOU CAN SEND THE TWIN T FILTERS OUTPUT SEPARATELY FOR INDIVIDUAL PROCESSING, BUT THEN THE VOLUME KNOBS MUST BE AT MAXIMUM POSITION AND YOU SHOULD LEVEL MIX ON THE RECEIVING DEVICE.

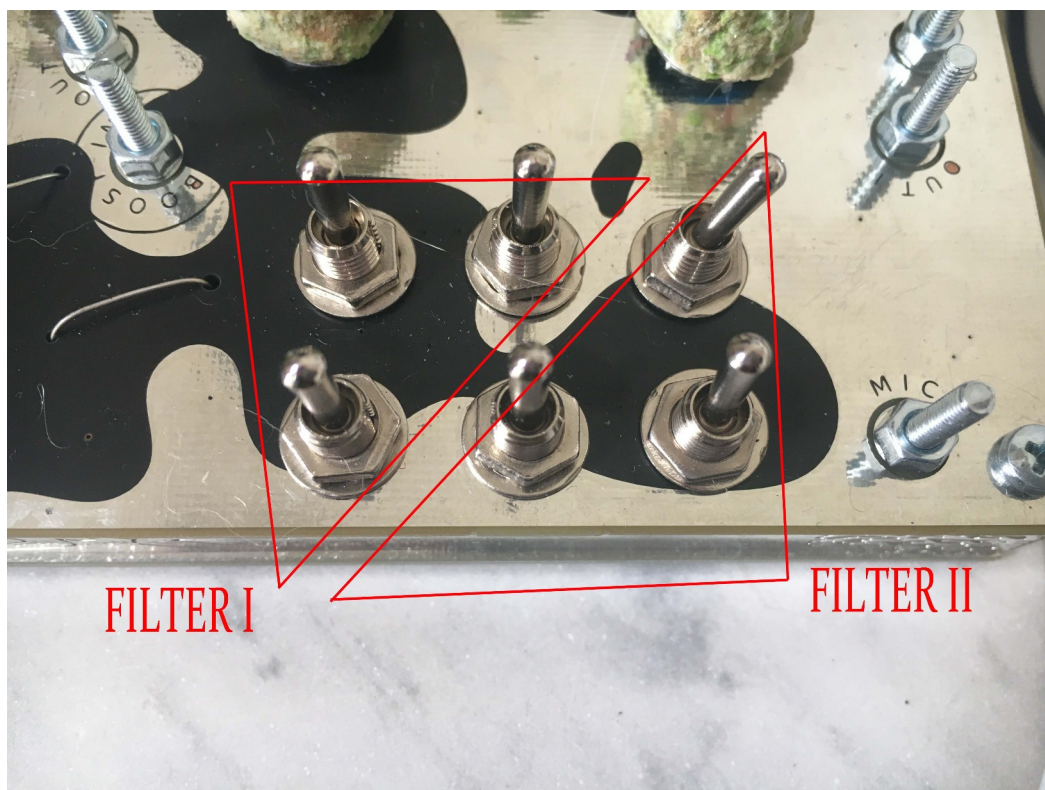

THE CAPACITOR SELECT SWITCHES ARE ARE RELATED AS SHOWN IN THE PHOTO. EACH GROUP OF 3 WAY SWITCHES CAN CHOOSE BETWEEN 8 CAPACITOR VALUES. EACH SWITCH IN ISOLATION WILL SWITCH BETWEEN 2 VALUES BUT THESE TWO VALUES DEPEND ON WHERE THE OTHER SWITCHES ARE SET. MANUAL SELECTION IS MADE BY PUTTING THE SWITCH IN THE CENTER OR RIGHT POSITION. IF A SWITCH IS IN THE LEFT POSITION, THEN THE OUTPUT OF THE RESPECTIVE CHAOS REGISTER WILL DETERMINE WHICH CAPACITOR IS SELECTED.

-----MIC-----

MIC IS THE CONTACT MIC PATCH POINT FOR CONNECTING THE INTERNALLY MOUNTED CONTACT MIC INTO THE FILTER OR INTO THE FINAL MIX OUTPUT

-----BOOST-----

BOOST IS A SIMPLE OVERDRIVE/BOOST. THERE WAS A BIT OF UNCERTAINTY ON MY PART AS TO WHETHER TO INCLUDE THIS. DUE TO THE NATURE OF THE FREE PATCHING INTERFACE - WHERE THE CIRCUIT RISES OUT OF THE CASE WHICH IS IN REALITY THE GROUND PLANE- GROUND HUM ISSUES CAN OCCUR WHEN CONNECTING THE CONTACT MIC DIRECTLY INTO THE BOOST. HOWEVER IT IS VERY USEFUL FOR PROCESSING EXTERNAL SOUNDS THAT YOU MIGHT WANT TO BRING INTO THE MACHINE, AND FOR PROCESSING THE TWIN T FILTERS TO ADD MORE WIDTH AND SATURATION. ALSO, YOU CAN CONNECT THE MIC INTO THE BOOST BY GOING THROUGH THE TWIN T FILTER. IF PATCHED IN THIS WAY YOU SHOULD NOT ENCOUNTER GROUND HUM.

-----FILTERS-----TECHNICAL
----- HISTORY -----
TECHNICAL-----

THE TWO TWIN T FILTERS FORM THE CORE OF 23. TWIN T IS A FILTER TOPOLOGY THAT WAS INVENTED IN THE EARLY PART OF THE 20TH CENTURY ORIGINALLY FOR EARLY TELEPHONE COMMUNICATION. AS YOU CAN SEE FROM THE CIRCUIT DIAGRAMS IN THE PATENT THERE ARE 2 RESISTOR CAPACITOR NETWORKS IN AN ARRANGEMENT THAT LOOKS LIKE 2 T'S.

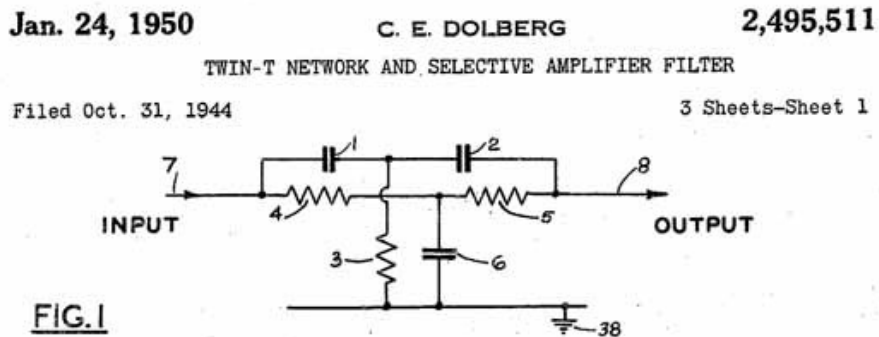

THIS ARRANGEMENT ESSENTIALLY FORMS 2 FILTERS- A HIGH PASS AND A LOW PASS FILTER WITH IDENTICAL CENTER FREQUENCIES. IN REALITY, IDENTICAL IS PHYSICALLY IMPOSSIBLE AS IS TOTAL BLOCKAGE OF SOUND AND INSTEAD A VERY NARROW BANDWIDTH ALLOWS SOUND THROUGH.

THE TWIN T ALSO HAS THE PROPERTY OF BEING HIGHLY VOLATILE WHEN AMPLIFIED AND FED BACK ON ITSELF. EVEN PHYSICALLY TOUCHING THE CIRCUIT WHEN IT IS IN THIS STATE IS ENOUGH TO MAKE IT SELF OSCILLATE WITH A SINUSOIDAL WAVE. SENDING A PULSE INTO IT WHEN IN THIS STATE WILL CAUSE IT TO CREATE A SOUND THAT HAS PROPERTIES SIMILAR TO AN ACOUSTIC PERCUSSION. AN IMPACT OF SOUND ENERGY RINGS OUT AND THEN DECAYS BACK TO SILENCE. BY THE 60'S IT WAS BEING USED IN MUSICAL CIRCUITS FOR THE WAH GUITAR SOUND AND THEN EARLY 70'S AND 80'S ROLAND AND OTHER INSTRUMENT COMPANIES

EXPLOITED THIS IN THE CLASSIC DRUM MACHINES FROM THAT TIME - 808, 909, 606, CR78, DR55, DR110, ALL THE EARLY ORGAN PERCUSSION UNITS ETC... THE 808 USES TWIN T FILTERS IN PRACTICALLY EVERY ONE OF ITS PERCUSSION SOUNDS.

THE TWIN T DOES NOT CONFORM TO MODERN PERFORMANCE EXPECTATIONS IN A NUMBER OF WAYS. FIRST OF ALL ITS FREQUENCY RANGE IS EXTREMELY LIMITED. DEPENDING ON THE CIRCUIT CONFIGURATION AND THE OPTIMIZATION OF COMPONENT VALUES IT CAN VARY FROM LESS THAN 1 OCTAVE TO A MAXIMUM OF AROUND 3.5 OCTAVES. ITS CONTROLS ARE VERY NON LINEAR AND ALSO EFFECT ONE ANOTHER. ADJUSTING PITCH EFFECTS FEEDBACK/DECAY AND VICE VERSA. THE PITCH FREQUENCY RESPONSE IS ALSO EXTREMELY NON LINEAR. IT WAS PROBABLY AT LEAST PARTLY DUE TO THIS THAT MOST OF THOSE CLASSIC DRUM MACHINES HAD FEW ADJUSTABLE PARAMETERS.

TODAY WE CAN APPRECIATE THIS STRANGE BEHAVIOR FOR WHAT IT IS - A PORTAL TO THE UNUSUAL AND UNEXPECTED. THOSE EARLY DRUM MACHINE DESIGNERS ELECTED TO USE THE TWIN T FILTER FOR REASONS THAT ARE INNATE TO ITS ACTUAL PHYSICAL COMPOSITION. AND THOSE SOUNDS BECAME CLASSIC STANDARDS DUE TO THEIR SPECIFIC SONIC PROPERTIES. TODAY THEY MIGHT SEEM BANAL IN THEIR UBIQUITY BUT WE CAN UNLOCK NEW POTENTIALS BY REVISITING THE ORIGINAL FORM AND OPENING UP THE PHYSICAL CIRCUIT TO A MUCH WIDER RANGE FOR EXPERIMENTATION.